

Randall

R100S STEREO SYNTH

The R100S is a true Synthized Stereo Effect. It takes a mono signal (one source) and converts this to Synthized Stereo with A & B or left and right outputs. The R100S Stereo Synth is the same type of Stereo Effect found on todays recordings. This effect is used on Guitar, Keyboards, Drums, Bass Guitar, Vocals and many other instruments.

The R100S is not a Phase Shifter, Digital Delay, Analog Delay, Compressor, Limiter, Flanger, Chorus of any other type of effect on the market today. Its most effective use is with matching amplifiers (with effects loops) or headphones.

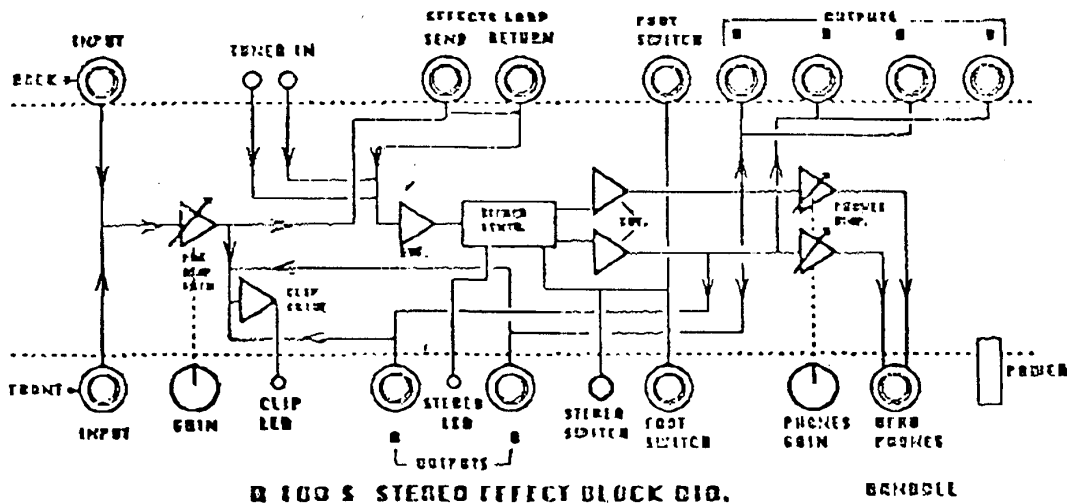

Randall

RANDALL INSTRUMENTS, INC.
1132 DURYE, IRVINE, CA 92714-5582
P.O. BOX 26037, SANTA ANA, CA 92799-6037

R100S

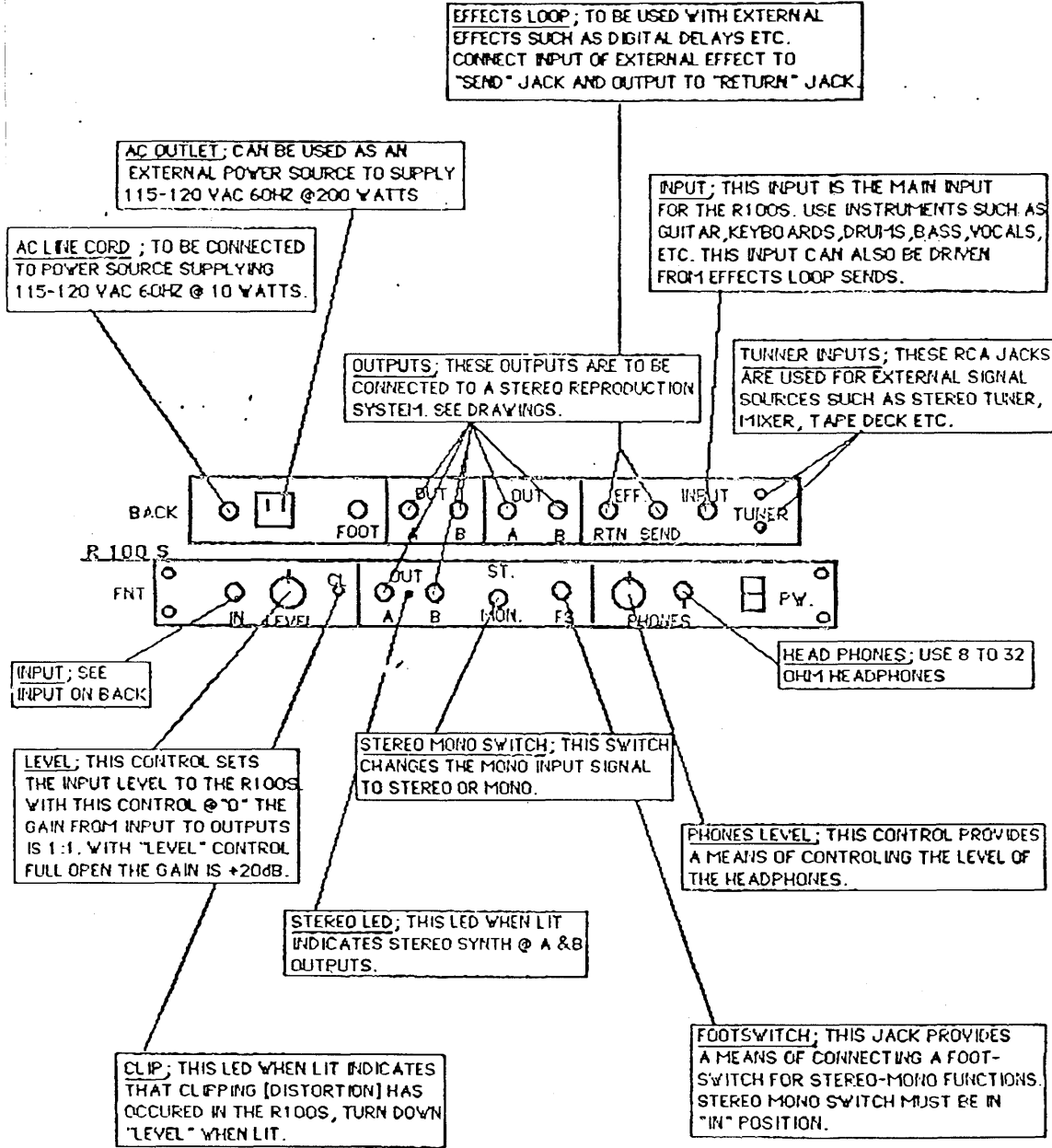

MAJOR CONNECTIONS USING THE RANDALL R100S AND OTHER OUTBOARD EQUIPMENT

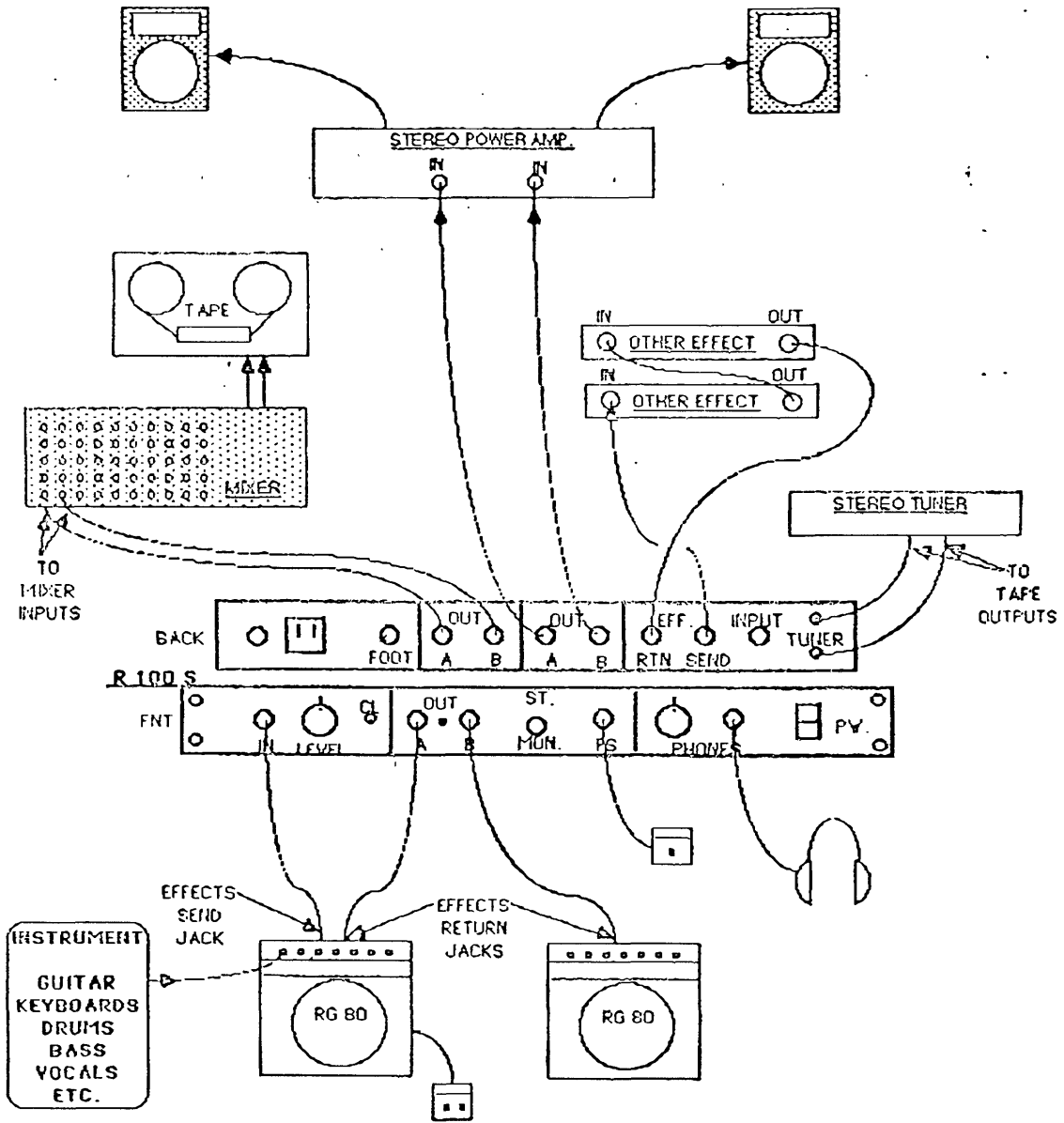

STEREO SYNTH MAIN SOUND REINFORCEMENT SYSTEM

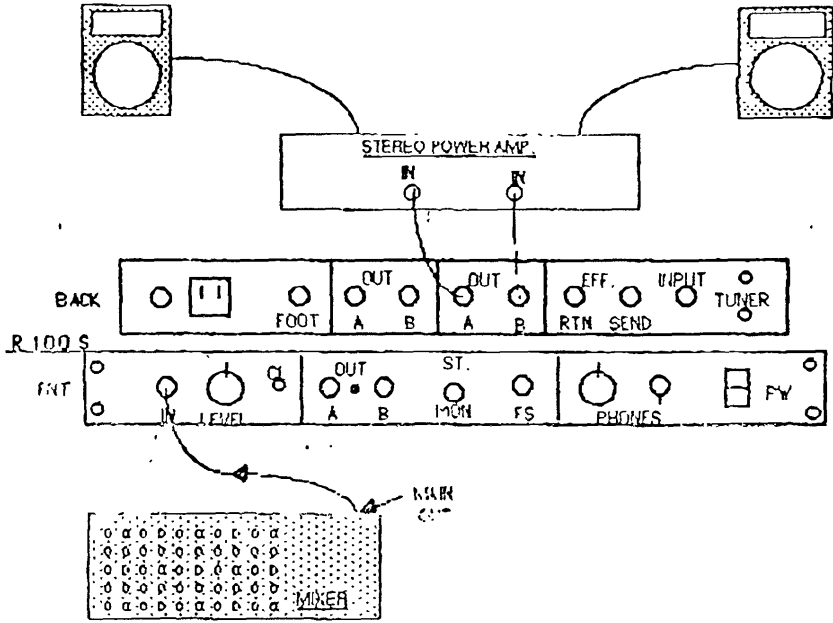

HOW TO STEREO SYNTH REAR CHANNELS

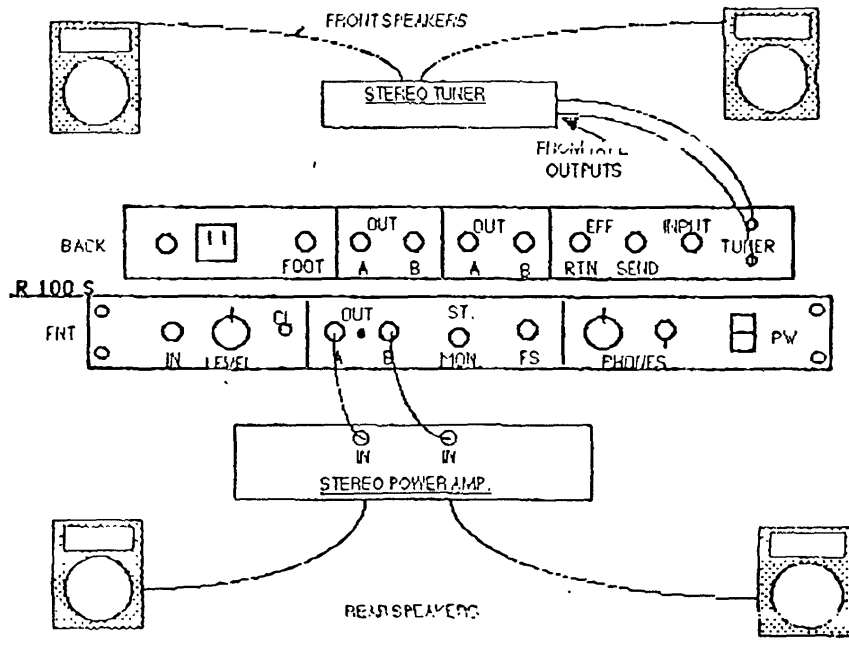

RANDALL IRVINE CA U.S.A.

MULTI TAP TRANSFORMER PRIMARY CONFIGURATION

1-26-89

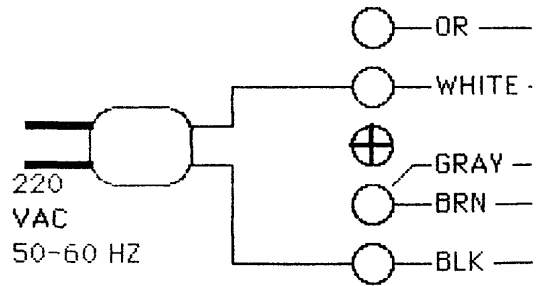
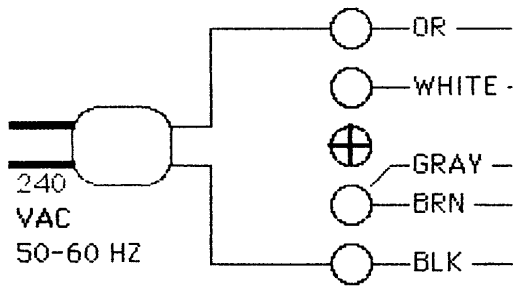
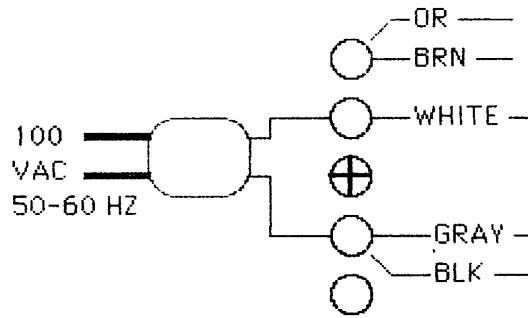
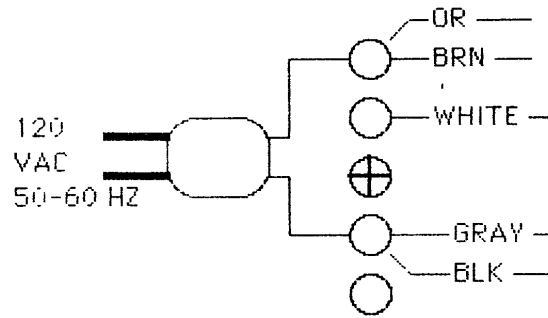
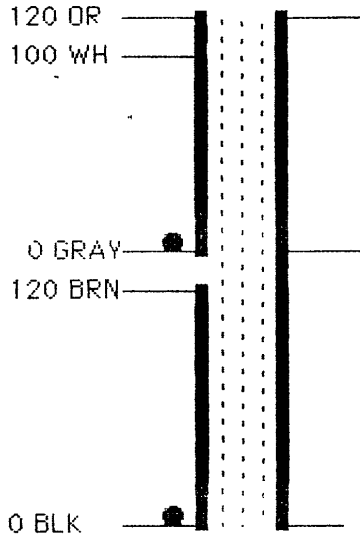

"PRIMARY WIRING" DRAW#7

NOTES:

- * INPUTS, OUTPUTS AND FOOTSWITCH JACKS CAN BE USED EITHER ON FRONT OR BACK PANELS.
- * USE SHIELDED CABLES ON ALL CONNECTIONS EXCEPT SPEAKER CABINET CONNECTIONS.
- * USE GROUND LIFTS ON COMPONENTS CAUSING GROUND LOOP HUMS. DO NOT DISCONNECT GROUND FROM 120 VAC 60 HZ MAIN SERVICE.

SIMPLE HEADPHONE PRATICE SETUP

